



Sunny Boy SB 3300TL HC Transformerless Solar Inverter



Table of Contents

1	Explanation of the Symbols Used	5
2	Foreword	7
2.1	Target Group	7
2.2	Appropriate Usage	7
3	Safety Instructions	9
4	Overview	11
4.1	Unit Description	11
4.2	External dimensions	12
5	Installation Requirements	13
5.1	Installation Site Requirements	13
5.2	PV Generator Requirements	15
5.3	Low-voltage Grid (AC)	15
6	Installation	19
6.1	Mounting the Unit	19
6.2	Electrical Installation	20
6.2.1	Connecting the AC Output	22
6.2.2	PV String (DC) Connection	24
6.3	Commissioning	25
7	Opening and Closing the Sunny Boy	27
7.1	Opening the Sunny Boy	27
7.2	Closing the Sunny Boy	27
8	Technical Data	29
8.1	PV Generator Connection Data	29
8.2	Grid Connection Data	30
8.3	General Data	31
8.4	Operating Parameters	33

8.4.1	Explanation of the Operating Parameters	33
8.4.2	Parameter Settings for Germany	36
8.4.3	Country-specific Parameter Settings	37
8.4.4	Fixed Parameters	38
8.5	Certificates.	39
8.5.1	CE Declaration of Conformity	39
8.5.2	SMA Grid Guard Certificate	40
9	Replacing the Varistors	41
10	Rating for a Line Circuit Breaker	45
11	The Communications Interface	49
11.1	Connection RS232, RS485, Radio Piggy-Back.	50
11.1.1	Jumper Functions	51
11.2	Powerline Connection	52
12	Contact.	57

1 Explanation of the Symbols Used

To ensure optimum use of these instructions, note the following explanation of symbols used.

This symbol identifies an example.



This symbol identifies a notice which, if not followed correctly, will make the procedure or operation more difficult.



This symbol indicates a fact which, if not observed, could result in damage to components or danger to persons. Please read these sections especially carefully.



2 Foreword

The Sunny Boy SB 3300TL HC is equipped with the SMA grid guard. This is a type of independent disconnection device. This means that the Sunny Boy SB 3300TL HC complies with the VDEW (Verband der Elektrizitätswirtschaft – German Electricity Industry Association) regulations for the connection and parallel operation of electrical power units to the low-voltage grid of the electricity supply company and with DIN VDE 0126-1-1, which forms a part of these regulations.



Refer to the operating manual for detailed information on troubleshooting and operating the Sunny Boy SB 3300TL HC.

"Sunny Design" will assist you in the system design and checking the string size for a given type of inverter. Further information on Sunny Design is available at www.SMA.de.

If you require further information, please call the Sunny Boy hotline on the following number:

(0561) 95 22 - 499

2.1 Target Group

Warning!

The Sunny Boy may only be installed by trained specialists. Installers must be approved by the local energy supplier. Read this "installation guide" carefully. Ensure compliance with all prescribed safety regulations, the technical connection requirements of the local energy supplier and any other applicable provisions.



This installation guide is exclusively intended for qualified electricians and is intended to assist with the speedy and correct installation and setup of the SMA Sunny Boy SB 3300TL HC inverter.

2.2 Appropriate Usage

Warning!

The Sunny Boy SB 3300TL HC is designed for operation in grid-connected PV systems. Any other use of the Sunny Boy SB 3300TL HC leads to loss of the the right to all warranty claims and may lead to a fault in the device. This includes, among other things, the operation at voltage sources without any current limit. When in doubt, contact SMA.



3 Safety Instructions

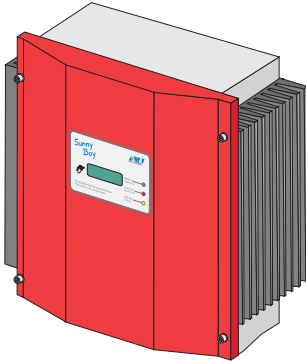

Warning! Overvoltage!

Check the system design using the "Sunny Design" design tool (www.SMA.de) or by calling the Sunny Boy Hotline. Overvoltages may lead to the destruction of the Sunny Boy SB 3300TL HC.



Warning! High voltage!

Work on the Sunny Boy with the cover removed must be carried out by a qualified electrician. High contact voltages are present in the device. The AC and DC voltages must be disconnected from the Sunny Boy and the capacitors must be discharged before working on the Sunny Boy with the cover removed.

The Sunny Boy must be disconnected from the mains grid and precautions must be taken to prevent the grid being accidentally reconnected. In addition, the connections to the PV generator must be disconnected.

After isolating the AC and DC voltage, you must wait approx. 30 minutes for the capacitors in the Sunny Boy to discharge. Only then is it safe to open the unit by removing the cover and make sure that no voltage is present in the device.



Warning! Electrostatic charge!

When working on the Sunny Boy SB 3300TL HC and handling its components, remember to observe all ESD safety regulations. Electronic components are susceptible to electrostatic charge. Discharge any electrostatic charge by touching the grounded housing before handling any electronic component.



4 Overview

4.1 Unit Description

The following diagram gives a schematic overview of the various components and connection points inside the Sunny Boy SB 3300TL HC with the cover removed:

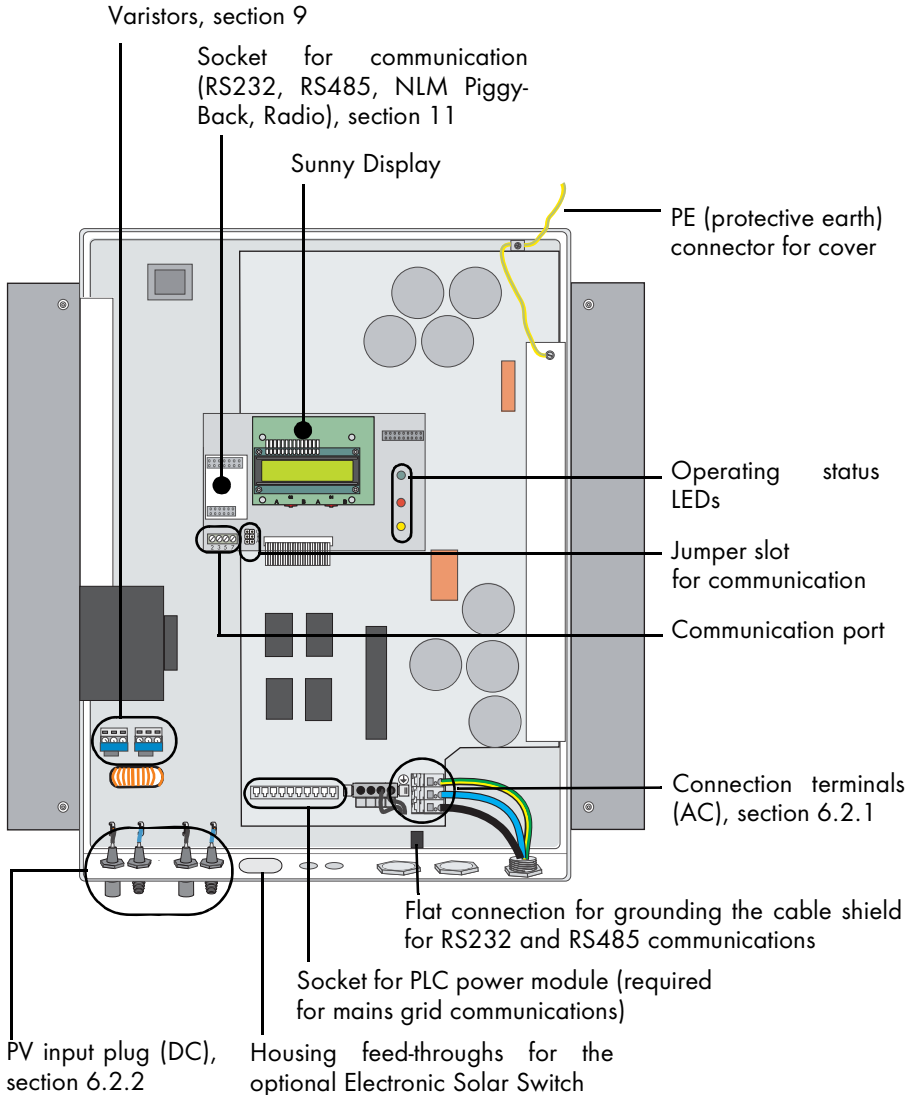

4.2 External dimensions

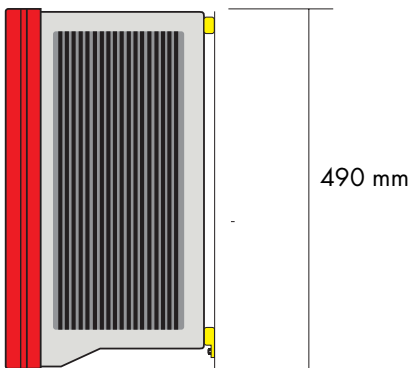
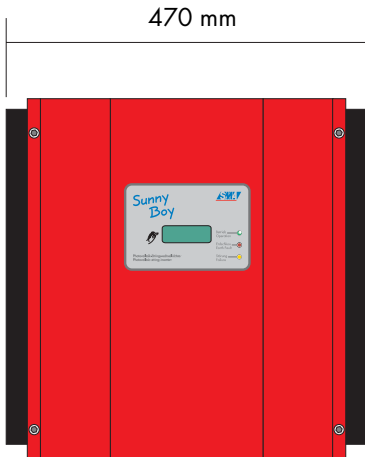
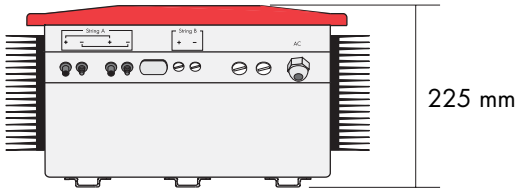

5 Installation Requirements

Check that all of the conditions listed below are met before installing and setting up the Sunny Boy.

5.1 Installation Site Requirements

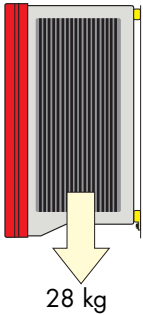

The Sunny Boy SB 3300TL HC weighs more than 28 kg. Take this weight into account when choosing the installation site and method of installation.

The ambient temperature must not be outside the -25 °C to $+60\text{ °C}$ range.



The Sunny Boy SB 3300TL HC is designed for outdoor installation and should be installed in a place where it is not exposed to direct sunlight. An increased ambient temperature can reduce the yield of the PV system. Installing the unit in badly ventilated, warm indoor locations may also reduce yield.

The Sunny Boy is designed to be mounted on a vertical wall. However, if absolutely necessary, the Sunny Boy can be installed tilted back at a maximum angle of 45° . Vertical installation at eye-level is preferable for an optimum energy yield and maximum operational comfort. If installing the unit outdoors, make sure that it is not slanting forward.

We advise against installing the unit in a horizontal position outdoors.

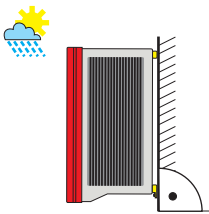

Install the inverter vertically or tilting backward.

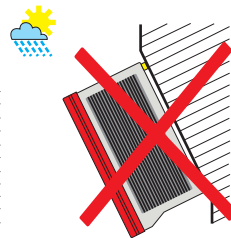
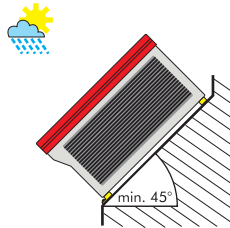

Never install the inverter horizontally or so that it tilts forward.



When choosing the installation site, be sure to note the following:



Warning, high voltage!

Unintentionally pulling out the DC plug connectors under load can damage the plugs and could result in personal injury! Install the Sunny Boy in such a way that it is not possible (e.g. for children) to unplug the DC plug connector unintentionally.



Warning, risk of burning!

The temperature of individual parts of the housing, in particular the temperature of the heatsink and the components inside the Sunny Boy, can reach more than 60 °C. Touching could result in burns!



Warning!

Do not install the Sunny Boy

- on flammable construction materials,
- in areas where highly inflammable materials are stored,
- in potentially explosive environments!

When choosing the installation site, ensure there is enough space for heat to dissipate. Under normal conditions, the following guidelines should be applied for the space to be kept clear around the Sunny Boy SB 3300TL HC:

	Minimum clearance
Sides	20 cm
Top	20 cm
Underneath	20 cm
Front	5 cm

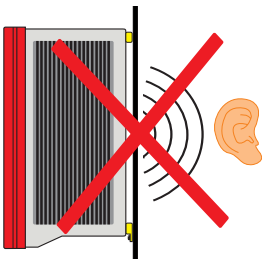
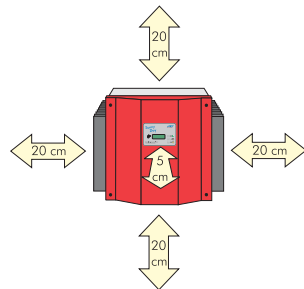

In domestic installations, the unit should not be mounted on plasterboard walls or alike as otherwise audible vibrations are likely to result.

We recommend securing the unit to a solid surface.

The Sunny Boy makes noises when in use which can be seen as a nuisance when installed in a living area.

5.2 PV Generator Requirements

The Sunny Boy SB 3300TL HC is designed to be connected to up to two strings having a homogenous structure (modules of the same type, identical orientation, tilt and number).

"Sunny Design" will assist you in the system design and checking of the string size for a given type of inverter. Further information on "Sunny Design" is available at www.SMA.de.

The unit has four DC plug connectors (two for each string) for connecting the PV generators. The connecting cables from the PV generators must also be fitted with this type of plug connector. The SMA order codes for the various connectors are as follows:

- Multi-Contact 3 mm: "SWR-MC"
- Multi-Contact 4 mm: "MC-SET"
- Tyco: "TYCO-SET"

Limit values for DC input	
Max. voltage	750 V (DC)
Max. input current	11 A (DC)

5.3 Low-voltage Grid (AC)

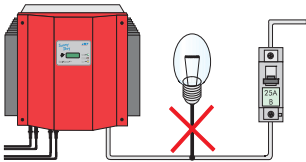

Caution!

The feed-in connection must be protected by a 25 A circuit breaker type B. No further devices must be connected to the secured cable.



The relevant technical regulations and the special instructions of the local grid operator must be followed.

The connection terminals of the Sunny Boy SB 3300TL HC are suitable for wire cross-sections of up to 10 mm². The external diameter of the cable must be between 9 mm and 17 mm. The connection is made with three wires (L, N, PE).

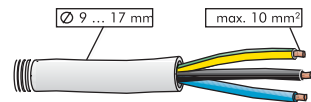

Rating for a Line Circuit Breaker in a Photovoltaic Electrical Power Unit Operated in Parallel with the Low-voltage grid

Various factors should be taken into account when selecting line circuit breakers. These include, for example:

- The type of cable used (conductor material and insulation)
- Ambient temperatures affect the cables (higher temperatures result in a reduced maximum current load)
- Method of routing the cable (reduces the maximum current load)
- Bundling cables together (reduces the maximum current load)
- Loop impedance $[Z]$ (in the event of a body contact this limits the current that can flow and therefore determines the response behavior of the circuit breaker)
- Sufficient distance between the circuit breakers so as to avoid undue heating (heat can trigger the circuit breaker early).
- Selectivity
- Protection class of the connected load (VDE 0100, part 410, "Protection against electric shock")



The following standards should be followed in all cases:

- DIN VDE 0298-4 (Cable routing and current-carrying capacity)
- DIN VDE 0100; part 430 (Protective measures "Protection of cables and cords against overcurrent")
- DIN VDE 0100; part 410 (Protective measures "Protection against electric shock")

Examples for rating a line circuit breaker are given in section 10 "Rating for a Line Circuit Breaker" (Page 45).



A 30 mA RCD or FI circuit breaker must not be installed.

The Sunny Boy SB 3300TL HC is equipped with an integrated universal current sensitive leakage-current breaker. The Sunny Boy SB 3300TL HC can automatically differentiate between real fault currents and "normal" capacitive leakage currents.

The Sunny Boy SB 3300TL HC does not generate any extraordinary leakage currents in normal operation. In certain operating states (e.g. during self-test of the protective equipment), leakage currents may occur which can trigger a "normal" 30 mA RCD or FI circuit breaker.

In case an RCD or FI circuit breaker is imperative, you must use a circuit breaker with a sensitivity of 100 mA or more.



Line Losses

AC cable system impedance should not exceed 1 ohm. This is necessary, amongst other things, for the correct operation of impedance observation. In addition, we recommend dimensioning the conductor cross-section so that line losses do not exceed 1 % at the nominal power. Line losses depending on the cable length and cross-section are shown in the graph below. Multi-wire cables with copper forward and return conductors are used.

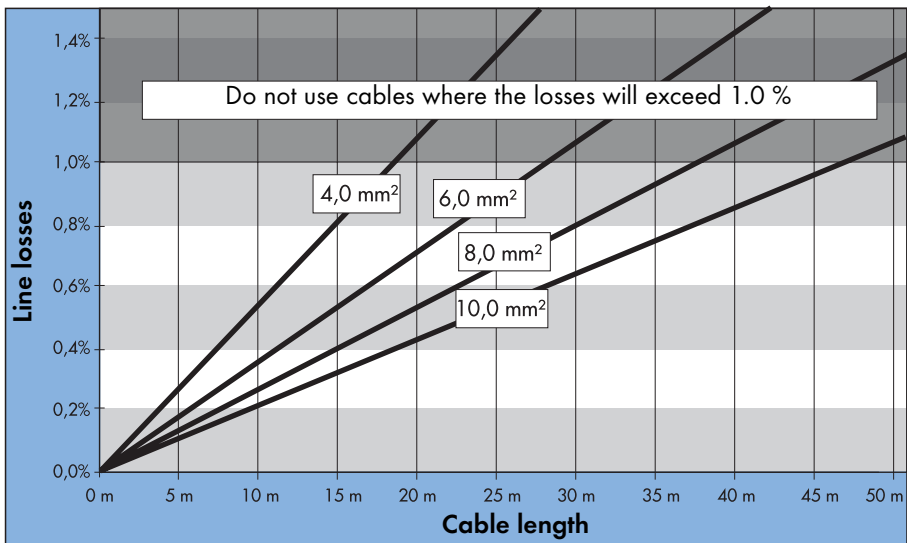

The maximum cable lengths for the different cable cross-sections are as follows:

Cable cross-section	4.0 mm ²	6.0 mm ²	8.0 mm ²	10.0 mm ²
Max. length	18 m	28 m	37 m	47 m

The Sunny Boy SB 3300TL HC is designed for operation on 220 - 240 V grids at a grid frequency of 50 Hz. When connecting an inverter to the public grid, follow the connection requirements of the local grid operator.

	Limit values for AC output
Voltage range (in the area of application of DIN VDE 0126-1-1)	198 V ... 253 / 260 V ^a
Frequency range (in the area of application of DIN VDE 0126-1-1)	47.55 Hz ... 50.2 Hz
Voltage range (extended operating range)	180 V ... 265 V
Frequency range (extended operating range)	45.5 Hz ... 54.5 Hz

- a The Sunny Boy can feed into the public grid at a maximum output voltage of 260 V for brief periods. According to DIN VDE 0126-1-1, however, the 10-minute average must not exceed a voltage of 253 V. That means, if the grid voltage is constantly 254 V (e.g.), the inverter disconnects itself from the grid. In this case, contact the local grid operator for assistance.

DIN VDE 0126-1-1 only applies in Germany. See section 8.4.3 "Country-specific Parameter Settings" (Page 37) for all other preset country values of your inverter.

6 Installation

6.1 Mounting the Unit

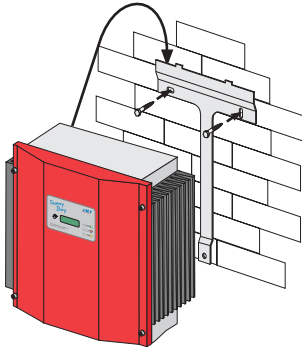

To make the job easier, we recommend you use the supplied wall bracket to mount the Sunny Boy SB 3300TL HC. For vertical installation on solid concrete or block walls, for example, you can fit the bracket using 8 mm x 50 mm hexagon bolts to DIN 571 standard, stainless steel type, and with wall plugs type SX10.

When selecting the mounting materials, be sure to take into account the weight of the Sunny Boy SB 3300TL HC (28 kg).

If you do not want to use the supplied wall bracket as a template, observe the dimensions shown in the drawing below. The procedure for mounting the inverter using the wall bracket is described on the following pages.

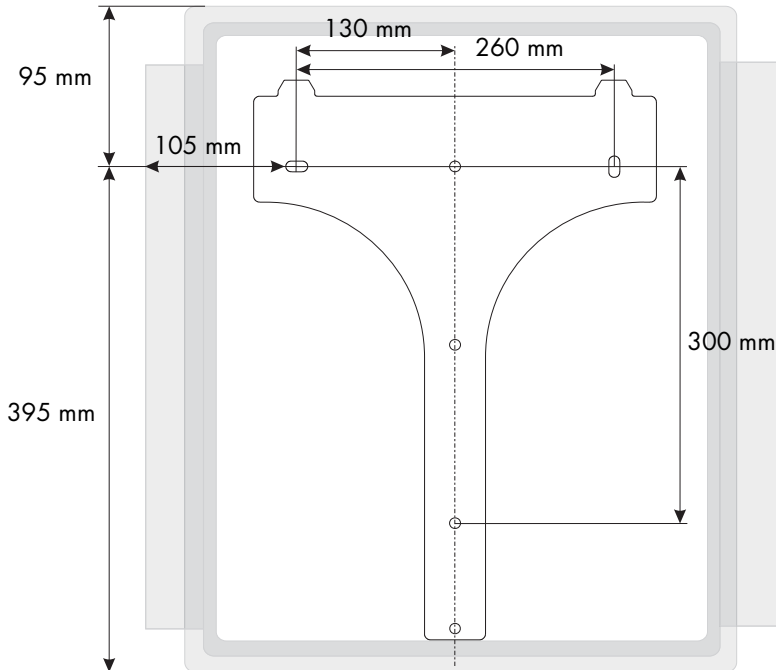

1. Fit the wall bracket (1). To mark the positions to drill the holes, you can use the wall bracket as a drilling template.
2. Now hang the Sunny Boy SB 3300TL HC onto the wall bracket (2) using its upper mounting plate so that it cannot be moved sideways.
3. Secure the Sunny Boy SB 3300TL HC in position by screwing the supplied M6x10 bolt into the central threaded hole at the bottom of the bracket (3).
4. Make sure that the Sunny Boy SB 3300TL HC is positioned securely on the bracket.

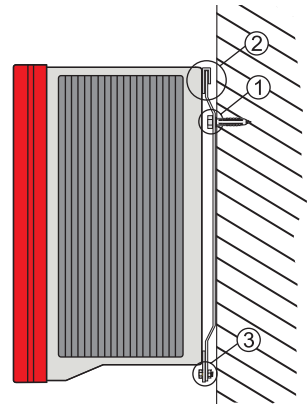

6.2 Electrical Installation



Warning!

Make sure to check the polarity of the strings before connecting them!

The complete wiring for a Sunny Boy SB 3300TL HC is shown schematically in the following diagram:

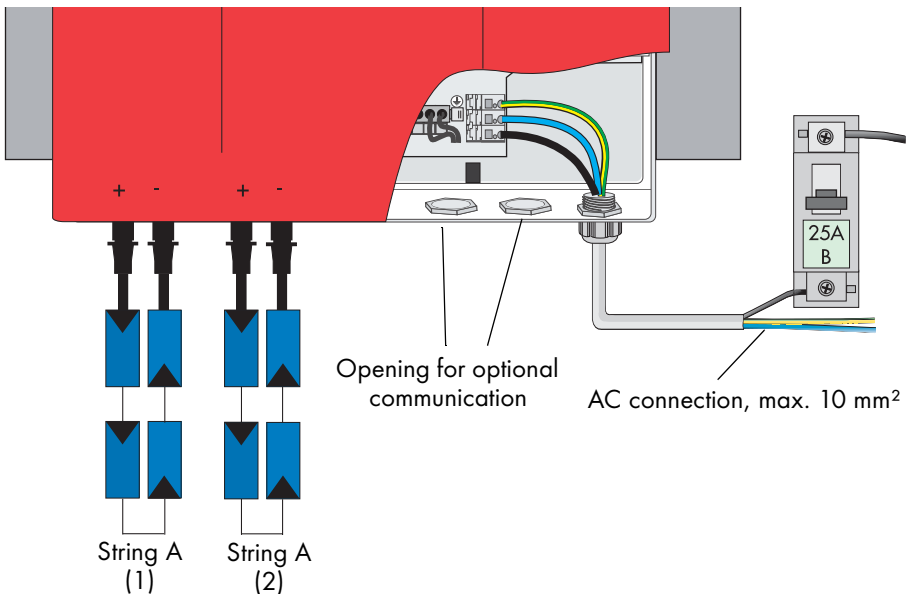

Sunny Boy SB 3300TL HC View from below

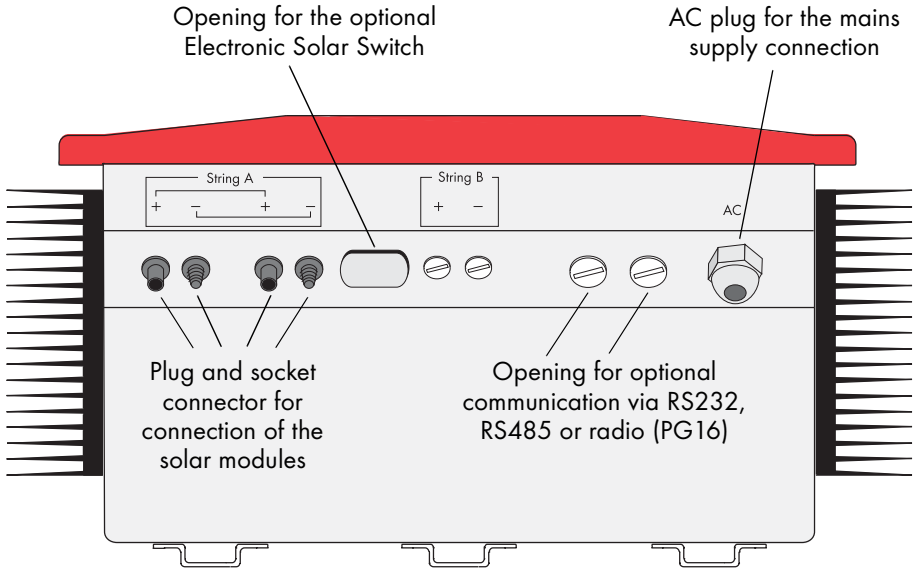

6.2.1 Connecting the AC Output

To connect the AC cable, proceed as follows:

1. Check the grid voltage. In the area of application of DIN VDE 0126-1-1, the Sunny Boy will not be fully operational if the grid voltage is constantly higher than 253 V. In this case, contact the local grid operator for assistance. The inverter can temporarily feed power into the grid with a maximum output voltage of 260 V. However, the 10-minute average must not exceed 253 V.

2. Isolate the grid connection (switch the line circuit breaker to its "off" position), make sure it cannot be switched back on, and test to make sure no voltage is present.

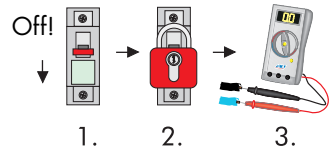

3. Remove the screws that secure the housing of the Sunny Boy SB 3300TL HC and carefully remove the cover. Remove the PE connection from the cover.

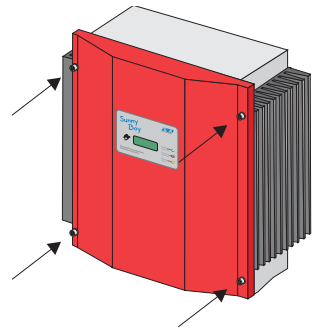

4. Connect the mains cable as shown in the figure. Use the supplied cable feed-through. **"L" and "N" must not be swapped.**

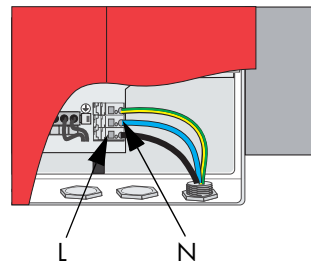

5. Connect the earth wire (PE) of the mains cable to the upper screw terminal with the earth sign.

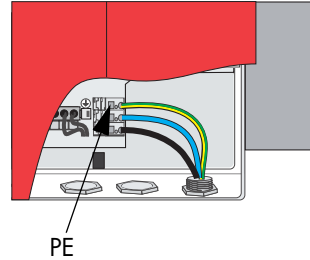

6. Reconnect the PE connection to the housing cover. Fix the housing cover of the Sunny Boy SB 3300TL HC and evenly tighten the four screws.

Warning!

Correct operation of your Sunny Boy requires, among other things, the connection of the PE conductor to the equipotential bonding of the building. Check the prescribed PE connection from the Sunny Boy housing to protective earth when commissioning the device!



Warning!

Do not switch the line circuit breaker on yet! The Sunny Boy SB 3300TL HC may only be connected to the AC grid once the PV strings are connected and the device is securely closed.



6.2.2 PV String (DC) Connection

To connect up the DC input, follow these steps:

1. Check that the PV generator connectors have the right polarity and do not exceed the maximum string voltage of 750 V (DC). See also section 5.2 "PV Generator Requirements" (Page 15).

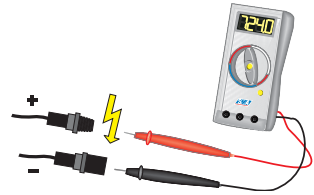

Warning!

Dangerously high voltages may be present. Danger of death!

2. Taking one DC plug connector at a time, measure the direct current voltage between one DC plug connector of a string and earth potential.
3. If the measured voltages are constant and their total is roughly the same as the open circuit voltage of the string, then there is a ground fault in this string. Its approximate location can be deduced from the relationships between the voltages.

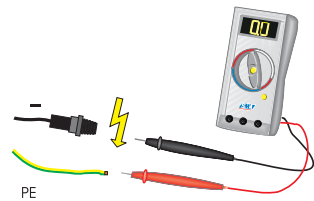

Warning!

Do not connect strings to the Sunny Boy SB 3300TL HC that contain a ground fault until you have fixed the earth fault in the PV generator.

4. Repeat points 2 and 3 for each string.
5. Connect up the faultless PV generator strings to the inverter.
6. Close the unused DC input sockets with the caps included in the delivery.

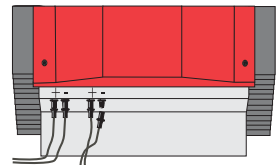

6.3 Commissioning

You can start up the Sunny Boy SB 3300TL HC when

- the housing cover is securely screwed shut,
- the AC (mains) cable is connected correctly,
- the DC cables (PV strings) are fully connected and the unused DC plug connectors on the bottom of the housing are closed using the protective caps.

How to Start up the Inverter

1. First of all, switch the line circuit breaker to the "on" position.

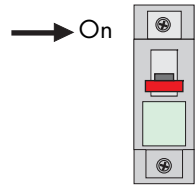

2. Now look at the LED display and consult the table on the following page to check whether the Sunny Boy SB 3300TL HC is in a fault-free and expedient operating mode. If this is the case, commissioning was successfully completed.

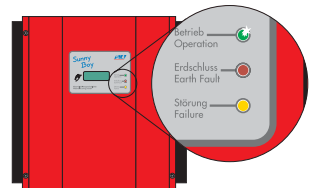

Warning!

If the bottom yellow LED flashes four times at intervals of one second, the grid voltage and the PV generator must be immediately disconnected from the Sunny Boy SB 3300TL HC! There is a risk of damage to the inverter resulting from excessive DC input voltage.



Check the string voltages again to make sure they are within the limits stated in section 5.2 "PV Generator Requirements" (Page 15). If the string voltages are too high, contact the planner / installer of the PV generator for assistance.

If despite checking the string voltages the LED signal occurs again when the PV generator is connected to the Sunny Boy SB 3300TL HC, disconnect the PV generator from the Sunny Boy again and contact **SMA Technologie AG** (see section 12 "Contact" (Page 57)).

Green	Red	Yellow	Status
illuminates continuously	is not illuminated	is not illuminated	OK (working mode)
	illuminates continuously	is not illuminated	fault
		illuminates continuously	OK (initialization)
flashes quickly (3 x per second)	is not illuminated	is not illuminated	OK (stop)
	illuminates continuously	is not illuminated	fault
flashes slowly (1 x per second)	is not illuminated	is not illuminated	OK (waiting, grid monitoring)
	illuminates continuously	is not illuminated	fault
briefly goes out (approx. 1 x per second)	is not illuminated	is not illuminated	OK (derating)
	illuminates continuously	is not illuminated	fault
is not illuminated	is not illuminated	is not illuminated	OK (night shutdown)
		illuminating/flashing	fault
	illuminates continuously	is not illuminated	fault
		illuminating/flashing	fault

For a detailed description of the fault messages and their causes, see the operating instructions.

7 Opening and Closing the Sunny Boy

Warning!

If you need to open the device for whatever reason, pay attention to section 3 "Safety Instructions" (Page 9).



7.1 Opening the Sunny Boy

Warning!

Follow the sequence below under all circumstances.



1. Switch the line circuit breaker to the "off" position.
2. Disconnect the PV generator from the Sunny Boy SB 3300TL HC.
- 3. Wait 30 minutes!**
4. Remove the four screws from the housing cover and pull the cover forward smoothly. At the same time remove the PE connection from the cover. Loosen the locking on the PE connectors on the cover when you remove them.

7.2 Closing the Sunny Boy

Warning!

Follow the sequence below under all circumstances.



1. Reconnect the earth wire (PE) to the housing cover. Now secure the housing cover of the Sunny Boy SB 3300TL HC by evenly tightening the four screws. The screws must be tightened with approximately 4 Nm torque in order to guarantee the sealing of the enclosure.
2. Connect the PV generator. Ensure the assignment of the strings is correct.
3. Switch the line circuit breaker to the "on" position.
4. Now check whether the LED display on the Sunny Boy SB 3300TL HC indicates that the device is functioning correctly.

8 Technical Data

8.1 PV Generator Connection Data

Description	Short des.	Setting
Max. input voltage ^{a)}	$U_{DC \max}$	750 V
Input voltage, MPP range	U_{PV}	125 V ... 750 V
Max. input current	$I_{PV \max}$	11 A
Max. input power	P_{DC}	3440 W
Voltage ripple	U_{pp}	< 10 % of the input voltage

- a) Ensure that the maximum input open circuit voltage, which can occur at a cell temperature of -10° , does not exceed the maximum input voltage.

8.2 Grid Connection Data

Description	Short des.	Setting
Nominal output power	P_{ACnom}	3000 W
Max. output power	P_{ACmax}	3300 W
Nominal output current	I_{ACnom}	13 A
Harmonic distortion of output current (at $K_{Ugrid} < 2\%$, $P_{AC} > 0.5 P_{ACnom}$)	K_{IAC}	< 4 %
Operating range, grid voltage	U_{AC}	180 ... 265 V AC Germany: 198 ... 253 / 260 V AC ^{b)}
Operating range, grid frequency	f_{AC}	45,5 ... 54.5 Hz Germany: 47,55 ... 50.2 Hz
Phase shift angle (based on the current's fundamental frequency)	cos phi	1 (at nominal power output)
Overvoltage category		III
Test voltage (50 Hz)		1.65 kV (1 s routine testing / 5 s type testing)
Test surge voltage		4 kV (1.2/50 ms) (serial interface: 6 kV)

- b) The Sunny Boy can feed into the public grid at a maximum output voltage of 260 V for brief periods. According to DIN VDE 0126-1-1, however, the 10-minute average must not exceed a voltage of 253 V. That means, if the grid voltage is constantly 254 V (e.g.), the inverter disconnects itself from the grid. In this case, contact the local grid operator for assistance.

DIN VDE 0126-1-1 only applies in Germany. See section 8.4.3 "Country-specific Parameter Settings" (Page 37) for all other preset country values of your inverter.

8.3 General Data

For a detailed description of the devices, see the operating instructions.

General data	
Protection degree acc. to DIN EN 60529	IP65
Dimensions (w x h x d)	470 mm x 490 mm x 225 mm (approx.)
Weight	28 kg (approx.)
Operating consumption	< 10 W (standby)
Own consumption in night mode	0.25 W

Protective function DC side	
All-pole isolator on the DC side	DC plug connector (ESS optional)
Overvoltage protection	thermally monitored varistors
Personal protection	ground fault monitoring (Riso > 1 MOhm)
Reverse polarity protection	Via short circuit diode

Protective function AC side	
Short-circuit strength	grid-side via current regulation
All-pole isolation on grid side	Independent disconnection device (SMA grid guard 2), double implementation

External interfaces	
Data transmission over mains power line	optional
Data transmission over separate data cable	optional, RS232 / RS485, galvanically isolated
Wireless data transmission	optional

Efficiency		
Max. efficiency	η_{max}	96 %
European standard efficiency	η_{euro}	94,6 %

The efficiency of the Sunny Boy SB 3300TL HC depends mainly on the input voltage of the connected PV strings. The higher the input voltage, the higher the efficiency.

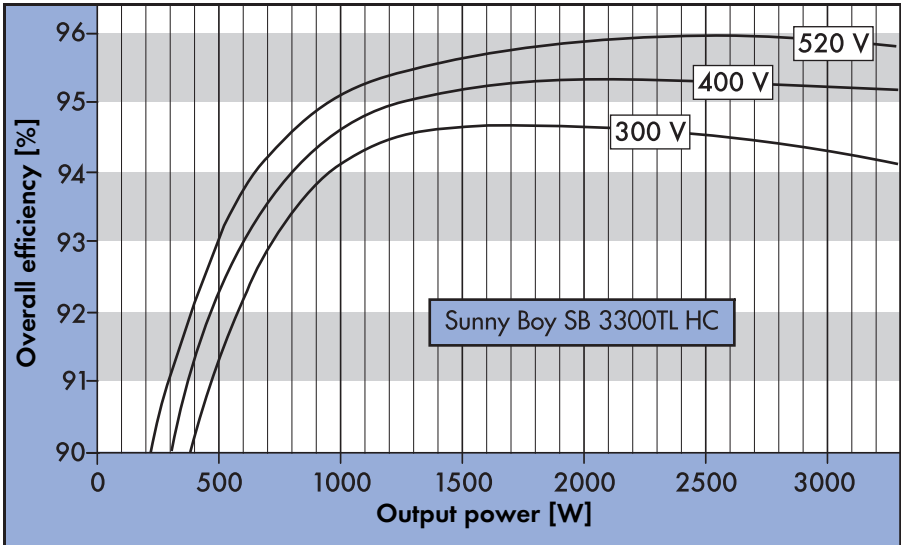

8.4 Operating Parameters

Warning!

Unauthorized changes to the operating parameters may result in:

- injury or accidents as a result of changing the internal safety routines in the Sunny Boy,
- voiding the Sunny Boy's operating approval certificate,
- voiding the Sunny Boy's guarantee.



Never change the parameters of your Sunny Boy without express authorization and instructions.

8.4.1 Explanation of the Operating Parameters

Name	Explanation
ACVtgRPro	Voltage rise protection (only relevant for Germany). Sunny Boys can feed into the public grid in Germany with up to 260 V AC. However, DIN VDE 0126-1-1 stipulates that the average AC voltage over 10 minutes must not exceed 253 V. If the average over 10 minutes exceeds the threshold value of 253 V, the inverter disconnects itself from the grid. Once the average over 10 minutes returns to a value of less than 253 V, the inverter returns to "Working" mode. If voltage rise protection is not required in the relevant grid area (outside Germany), it can be deactivated by means of presetting the LDVtgC parameter. In this event, only the fast cut-off via the Uac-Max parameter intervenes.
Antilsland-AmpI	Amplification of the Antilsland process (alternative Antilslanding process, which is deactivated for Germany).
Antilsland-Freq	Repetition rate of the Antilsland process (alternative Antilslanding process, which is deactivated for Germany).
Betriebsart / Operating Mode	Operating mode of the Sunny Boy: MPP: Maximum Power Point UKonst: Constant voltage mode (desired voltage is defined in "Usoll-Konst") IKonst: Operating mode for test purposes Stopp: Disconnection from mains network, no operation

Name	Explanation
Default	<p>Used for setting the country specific-information.</p> <p>GER/VDE0126-1-1: Country-specific parameter settings for Germany in accordance with DIN VDE 0126-1-1</p> <p>IT/DK5940: Country-specific parameter settings for Italy</p> <p>Other: Here, parameter settings can be defined for countries for which no predefined setting exists.</p> <p>Trimmed: If country-specific parameters have been changed, "trimmed" is shown in the display.</p>
dFac-Max	Maximum "grid frequency change" before the grid monitoring system disconnects the device from the grid.
dZac-Max	Maximum "grid impedance change" before the grid monitoring system disconnects the device from the grid.
E_Total	Total energy yield for the inverter. This change may be necessary when you replace the Sunny Boy and want to use the data stored in the old device.
Fac-delta-	Maximum frequency, above (Fac-delta+) and below (Fac-delta-) the grid frequency, before the grid monitoring system disconnects the device from the grid.
Fac-delta+	
Fac-Tavg	Averaging time of grid frequency gaging
Firmware-BFR	Firmware version of the operation control unit (BFR)
Firmware-DC-BFS	Firmware version of the DC operation control unit (DC-BFR)
FirmwareSRR	Firmware version of the current control unit (SRR)
h_Total	Total hours of operation for the inverter. This change may be necessary when you exchange the Sunny Boy and want to use the data from the old device.
Hardware-DC-BFS	Hardware version of the DC operation control unit (DC-BFR)
Inst.-Code	Parameters for self contained power system recognition can only be changed after entering the "SMA grid guard" password.

Name	Explanation
LDVtgC	<p>Compensation for the voltage drop in the cabling.</p> <p>With this parameter, the voltage drop between the inverter and the grid connection point is taken into account. The 10-minute average voltage at the inverter connection must not exceed the sum of ACVtgRPro plus LDVtgC. The parameter LDVtgC is preset to 0 V for Germany. The parameter LDVtgC is preset to 50 V for grid areas in which the additional voltage rise protection is not required (see parameter ACVtgRPro). Thus, the surge voltage protection is deactivated for these grid areas (253 V + 50 V = 303 V) and only the fast cut-off via the Uac-Max parameter intervenes.</p>
NiTest	Setting the impulse for impedance monitoring. This parameter only functions when the Sunny Boy is deactivated (disconnected on the AC side) or in "Stopp" mode.
Plimit	Upper limit for AC output power
Ripple-Ctl-Frq	<p>The Ripple-Ctl-Frq, Ripple-Ctl-Lev, Ripple-Ctl-Rcvr parameters are intended to handle ripple control signals from the SMA inverters. These parameters are not available for all inverters. These parameters may only be changed after prior agreement with SMA Technologie AG.</p>
Ripple-Ctl-Lev	
Ripple-Ctl-Rcvr	
Riso-Min	Lower limit of the permitted insulation resistance
SMA-Grid-Guard	SMA grid guard version number
SMA-SN	Serial number of the Sunny Boy
Speicherfunkt.	<p>Default parameter: Returns all parameter values to the factory setting.</p> <p>Reset Betriebsdaten: Returns all user level parameter values to the factory setting.</p> <p>Reset Fehler: Resets a permanent fault.</p>
T-Start	The period the Sunny Boy waits after all switch-on conditions have been satisfied.
Uac-Min	<p>Lower (Uac-Min) and upper (Uac-Max) limits of the allowable AC voltage (self contained power system recognition), before the grid monitoring system disconnects the device from the grid.</p>
Uac-Max	
Uac-Tavg	Averaging time of grid frequency gaging
Uzww-Start	The DC voltage required before the Sunny Boy begins feeding power into the mains supply.

Name	Explanation
Usoll-Konst DC	PV desired voltage for constant operational voltage. These parameters are only important when the "Betriebsart" parameter is set to U-konst.

8.4.2 Parameter Settings for Germany

Grayed out parameters are only displayed in installer mode. The table below contains the parameters that are applicable in Germany.

Name	Unit	Value range	Factory setting
ACVtgRPro	V	230 ... 300	253
Antilsland-Ampl *	grd	0 ... 10	0
Antilsland-Freq *	mHz	0 ... 2000	500
Betriebsart		MPP, IKonst, UKonst, Stopp	MPP
Default *		GER/VDE0126-1-1, IT/DK5940, Other, trimmed	GER/VDE0126-1-1
dFac-MAX *	Hz/s	0,1 ... 4,0	4,0
dZac-MAX *	mOhm	350 ... 20000	700
E_Total	kWh	0 ... 200000	0
Fac-delta- *	Hz	0,1 ... 4,5	2,45
Fac-delta+ *	Hz	0,1 ... 4,5	0,19
h_Total	h	0 ... 200000	0
Ni-Test *		0 / 1	1
Inst.-Code			
Ripple-Ctl-Rcvr		enable, disable, auto	disable
Ripple-Ctl-Lev	%	0,5 ... 8,00	1,70
Ripple-Ctl-Frq	Hz	110 ... 1600	216,7
Riso-Min	kOhm	1500 ... 30000	1500
Speicherfunktion		Default Parameter, Reset Betriebsdaten, Reset Fehler	None

Name	Unit	Value range	Factory setting
T-Start *	s	2 ... 300	2
Uac-Min *	V	160 ... 230	198
Uac-Max *	V	230 ... 300	260
Usoll-Konst DC	V	0 ... 750	290

Parameters designated with * are safety-related grid monitoring parameters. To change the SMA grid guard parameters, you must enter your personal SMA grid guard password (Inst.-Code). Call the Sunny Boy Hotline to obtain your personal SMA grid guard password.



8.4.3 Country-specific Parameter Settings

The parameters listed below represent country-specific settings and are only displayed in installer mode. All other parameters are international and can be viewed in the table in section 8.4.2.

Name	Unit	Country settings	
		Germany	Italy
Default		GER/VDE0126-1-1	IT/DK5940
dFac-Max	Hz/s	4,0	0,20
dZac-Max	mOhm	700	350
Fac-delta-	Hz	2,45	0,29
Fac-delta+	Hz	0,19	0,29
Ni-Test		1	0
T-Start	s	2	2
Uac-Min	V	198	198
Uac-Max	V	260	260

8.4.4 Fixed Parameters

The following parameters are displayed in the parameter list but cannot be changed:

Name	Unit	Factory setting
Fac-Tavg	ms	160
Firmware-DC-BFR		
Hardware-DC-BFR		
Plimit	W	3300
SMA-Grid-Guard		
SMA-SN		
Software-BFR		
Software-SRR		
Uac-Tavg	ms	80

8.5 Certificates

8.5.1 CE Declaration of Conformity

CE Declaration of Conformity



for utility interactive inverters

Product: Sunny Boy
Type: SB 700, SB 1100, SB 1100LV, SB 1700, SB 2100TL,
 SB 2500, SB 2800i, SB 3000, SB 3300TL, SB 3300TL HC

We declare that the above specified devices are compliant with the regulations of the European Community, in terms of the design and the version fabricated by SMA. This especially applies for the EMC Regulation defined in 89/336/EWG and the LV- regulation defined in 73/23/EWG.

The devices are compliant with the following standards:

EMC:	
Emission:	DIN EN 61000-6-3: 2002-08 DIN EN 61000-6-4: 2002-08 DIN EN 55022: 2003-09, Class B
Utility Interference:	DIN EN 61000-3-3: 2002-05 DIN EN 61000-3-2: 2001-12
Immunity:	DIN EN 61000-6-1: 2002-08 DIN EN 61000-6-2: 2002-08
Safety:	DIN EN 50178: 1998-04
Semiconductor-Converter:	DIN EN 60146-1-1: 1994-03

The above mentioned devices are therefore marked with a CE sign.

Note:

- This declaration of conformity becomes invalid in case
 - the product is modified, complemented or changed,
 - and/or components, other than those belonging to the SMA accessories, are installed in the product,
 - as well as in case of incorrect connection or improper usage
- without explicit written confirmation by SMA.

Niestetal, 13.03.2006

SMA Technologie AG

i.V. Frank Greizer
 i.V. Frank Greizer

(Head of Development Department Solar Technology)

SMA Technologie AG

Hannoversche Strasse 1-5
 34266 Niestetal
 Tel. +49 561 9522 - 0
 Fax +49 561 9522 - 100
 www.SMA.de
 info@SMA.de



SB-K16ACE12BE1706

8.5.2 SMA Grid Guard Certificate

The Sunny Boy is equipped with the independent disconnection device "SMA grid guard" and it is covered by the industrial trade association "SMA grid guard" import certificate.

<p>Fachausschuss Elektrotechnik der Berufsgenossenschaftlichen Zentralen für Sicherheit und Gesundheit - BSGZ des Hauptverbandes der gewerblichen Berufsgenossenschaften</p>				
<p>SMA Technologie AG Hannoversche Straße 1-5 34266 Niestetal</p>		<p>Technische Einzelurteil, Postfach 21 22 90, 32641 Kila</p>		
<p>Das Zertifikat/Produkt ist von</p>	<p>Unter Nummer/Bezeichnung</p> <p>UB.010.17</p>	<p>Bezeichnet</p> <p>PV-Ös</p>	<p>☎ 022 231 37 79</p> <p>6312</p>	<p>Datum</p> <p>25.01.2006</p>
Unbedenklichkeitsbescheinigung				
Erzeugnis:	Selbsttätig wirkende Schaltstelle (ENS)			
Typ:	SMA grid guard Version 2			
Bestimmungsgemäße Verwendung:	Selbsttätig wirkende, dem VNB unzugängliche Schaltstelle als Sicherheitschnittstelle zwischen einer Eigenenerzeugungsanlage und dem Niederspannungsnetz. Gleichwertiger Ersatz für eine jederzeit dem VNB zugängliche Schaltstelle mit Trennfunktion.			
Prüfgrundlage:	DIN V VDE V 0126-1-1 (2006-02) "Selbsttätige Schaltstelle zwischen einer netzparallelen Erzeugungsanlage und dem öffentlichen Niederspannungsnetz"			
Das Sicherheitskonzept des o.g. Erzeugnisses, entspricht den zum Zeitpunkt der Ausstellung dieser Bescheinigung geltenden sicherheitstechnischen Anforderungen für die aufgeführte bestimmungsgemäße Verwendung.				
Die Unbedenklichkeitsbescheinigung wird spätestens				
31.12.2010				
ungültig.				
<p>- Mellem - Leiter der Prüf- und Zertifizierungsstelle</p>				
*Herausgeber	Direktion Hannover/BG 1.22	©2006 BGK	☎ 022 231 37 79-4400	☎ 022 231 37 79-63 23

9 Replacing the Varistors

The Sunny Boy SB 3300TL HC is a complex high-technology device. As a result, the possibilities for fixing faults on site are limited to just a few items. Do not attempt to carry out repairs other than those described here. Use the **SMA Technologie AG** 24-hour exchange service and repair service instead.

If the red LED on the status display glows continuously during operation, you should first of all make sure that there is no ground fault in the PV generator. Only skip points 3 to 5 if the green LED is permanently lit at the same time.

1. Disconnect the Sunny Boy SB 3300TL HC from the low-voltage grid (switch the line circuit breaker to its "off" position). Make sure the grid cannot be inadvertently reconnected and test to make sure no voltage is present at the AC output.
2. Disconnect the DC plug connectors for all strings.
3. Taking one DC plug connector at a time, measure the voltages between one DC plug connector of a string and earth potential. Pay attention to the safety instructions!

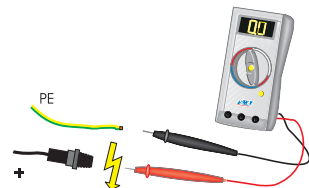
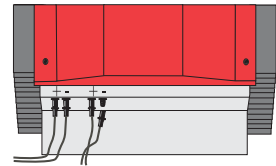
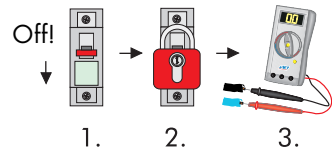

Warning!

Dangerously high voltages may be present. Danger of death!



4. If the measured voltages are constant and if their total is roughly the same as the open circuit voltage of the string, then there is a ground fault in this string. Its approximate location can be deduced from the relationships between the voltages.
5. Repeat points 3 and 4 for each string.
6. If you found a ground fault, it is probably not necessary to replace the varistors. Instead, make sure the ground fault is fixed. Generally the PV generator's installation engineer should be hired for this job. In this case continue as described

under point 10, but without reconnecting the faulty string. Instead of reconnecting the string, protect its DC plug against accidental touch contact (e.g. by fitting the protective caps or using sufficient high-voltage insulating tape).

If you did not find any ground fault in the PV generators, it is likely that one of the thermally monitored varistors has lost its protective function. These components are wearing parts. Their functioning diminishes with age or following repeated responses as a result of overvoltages. You can now check these varistors in the following way, paying attention to the safety instructions in section 3 "Safety Instructions" (Page 9):

7. Remove the screws that secure the cover and remove the cover from the Sunny Boy SB 3300TL HC. Disconnect the PE connection from the cover. Make sure that no voltage is present.
8. Using a continuity tester, check all the varistors to see if there is a conducting connection between connectors 2 and 3. If there is no connection, then that varistor is not working. The positions of the varistors in the Sunny Boy SB 3300TL HC can be seen in the figure in section 4.1 "Unit Description" (Page 11).

9. Replace the varistor concerned with a new one as shown in the drawing to the right. Ensure the varistor is installed the right way round! If you do not receive a special tool for operating the terminal clamps with your replacement varistors, contact SMA. As an alternative, the terminal contacts can be operated using a suitable screwdriver. Since the failure of one varistor is generally due to factors that affect all varistors in a similar way (temperature, age, inductive overvoltages), it is highly recommended that you replace all four varistors, not just the one that is obviously defective. The varistors are specially manufactured for use in the Sunny Boy SB 3300TL HC and are not commercially available. They must be ordered directly from **SMA** Technologie AG (SMA order code: "MSWR-TV7").

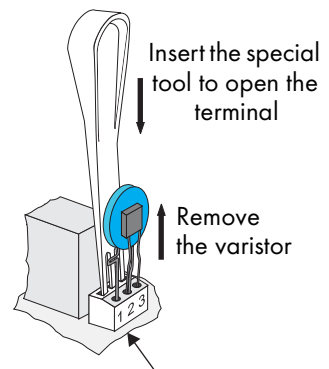

The pole with the small loop (crimp) must be fitted to terminal 1 when replacing the varistor.

10. If no replacement varistors are available on site, the Sunny Boy SB 3300TL HC can temporarily run without them. To do this, remove the varistors you identified as being faulty and in their place, bridge the terminals 2 and 3 with a length of wire.

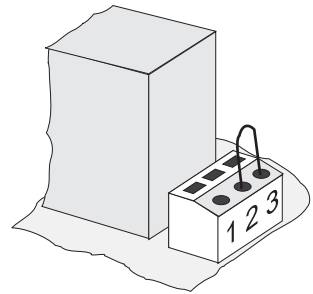

The input modified in this way is no longer protected against overvoltages! Replacement varistors should be obtained as soon as possible. The Sunny Boy SB 3300TL HC should not be operated without varistors in systems having a high risk of overvoltages!



11. Reconnect the PE connection on the cover and close the Sunny Boy SB 3300TL HC.
12. Connect up the faultless PV generator strings to the inverter. Ensure the assignment of the strings is correct.
13. Close the unused DC input sockets with the caps included in the delivery of the inverter.
14. Switch the line circuit breaker to the "on" position.

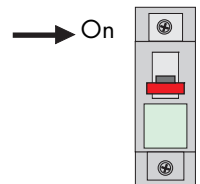
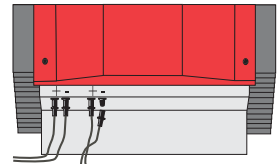

15. Now check whether the LED display on the Sunny Boy SB 3300TL HC indicates that the device is functioning correctly.

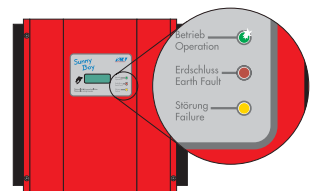

If no ground fault and no defective varistor were found, there is probably a fault in the Sunny Boy. In this case, contact the SMA hotline to discuss what to do next.

10 Rating for a Line Circuit Breaker

Example for the thermal rating for a line circuit breaker in a photovoltaic power-generating system operated in parallel with the low-voltage grid.

We assume a PV system with 9 Sunny Boy SB 3300TL HC inverters, with three inverters per phase.

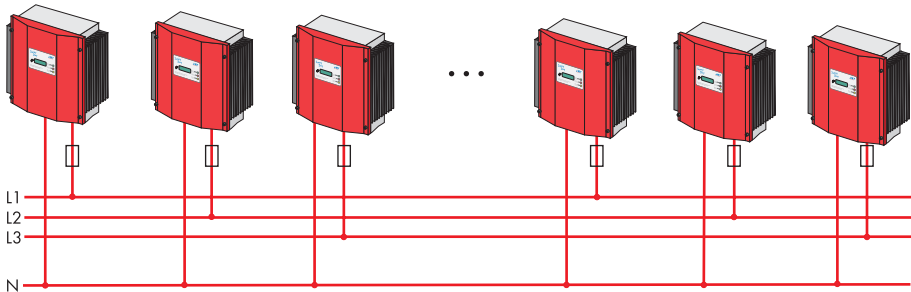

Required technical information for the inverters used

- Maximum output current = 16 A
- Maximum permissible fuse protection for the inverter = 25 A

The choice of cable together with the way it is routed, ambient temperatures and other underlying conditions limit the maximum fuse protection for the cable.

- In our example we assume that the chosen cable (4 mm²) is ideally routed and can take a nominal current of 25.2 A.

Selecting a Line Circuit Breaker:

- The maximum possible nominal current for the cable used and the maximum possible fuse protection for the inverter now limit the maximum possible nominal current for the line circuit breaker.
- In our example, 25 A is possible.

However, the thermal suitability of the line circuit breaker still needs to be checked.

When selecting line circuit breakers, a number of load factors need to be taken into account. These can be found in the respective data sheets.



Example for the thermal selection of a 25 A line circuit breaker with B sensitivity with no gap between the circuit breakers:

For example, one manufacturer's circuit breaker may be designed for an ambient temperature of 50 °C.

Load factors according to data sheet specifications:

- Reduction through permanent load $>1 \text{ h} = 0.9^1$
- Reduction factor when 9 circuit breakers are arranged side-by-side without gaps = 0.77^2
- Increase in nominal current as a result of ambient temperatures of 40 °C in the circuit breaker panel = 1.07^3

Result:

The nominal load current for the line circuit breaker is calculated as:

$$I_{bn} = 25 \text{ A} \times 0.9 \times 0.77 \times 1.07 = 18.5 \text{ A}$$

-
1. Permanent loads of longer than 1 hour are possible in photovoltaics.
 2. When only one circuit breaker is used, this factor = 1
 3. Due to the fact that the circuit breakers are rated for 50 °C

Summary:

The selected line circuit breaker can be used in our example case since the maximum current-carrying capacity for fault-free operation is higher than the maximum output current of the inverter used. It will not trigger under rated operating conditions! If the calculated current-carrying capacity of the circuit breaker had been lower than the maximum output current from the inverter, the following solution might have been used:

By spacing the circuit breakers at an interval of 8 mm, the reduction factor would be 0.98 instead of 0.77. As a result, the maximum current-carrying capacity would be 23.6 A.

In addition to the thermal rating of the circuit breakers, the boundary conditions as laid out in section "Rating for a Line Circuit Breaker in a Photovoltaic Electrical Power Unit Operated in Parallel with the Low-voltage grid" (Page 16) and the applicable DIN VDE standards also need to be taken into account, of course. The main ones that apply here are:

- DIN VDE 0100; part 410
- DIN VDE 0100; part 430
- DIN VDE 0298; part 4

In special applications the relevant standards must be followed.

11 The Communications Interface

Installation or replacement of the communications interface is only to be carried out by a trained electrician.



The communications interface is used to communicate with SMA communication devices (e. g. Sunny Boy Control, Sunny WebBox) or a PC with appropriate software (e.g. Sunny Data). Depending on the selected communications interface, up to 2500 inverters can be interconnected. Detailed information on this topic can be found in the communication device manual, the software, or on the Internet at www.SMA.de.

Depending on the type of interface, there are two different ways to install the communications interfaces:

- RS232, RS485, Radio Piggy-Back
(see section 11.1 "Connection RS232, RS485, Radio Piggy-Back" (Page 50))
- Powerline
(see section 11.2 "Powerline Connection" (Page 52))

The detailed wiring diagram for each communications interfaces can be found in the communication device manual. This wiring diagram includes:

- Details on the required cable type
- Which of the inverter's connections are used
- Whether jumpers need to be mounted, and if so, which jumpers
- Whether the PE needs to be connected to the cable shield

The next pages will describe the following:

- The housing feed-throughs for the communications interface
- The permitted cable route in the Sunny Boy
- The location of the PE connector
- The location of the screw terminals for connection of communication wires
- The location of the jumper slots
- The location of the interface port
- The location of the interface port for the PLC power module and the powerline modem

11.1 Connection RS232, RS485, Radio Piggy-Back

This section describes the installation of the Piggy-Backs for the different Sunny Boy communication systems. RS232 Piggy-Back (SMA order number: 232PB-MS-NR), RS485 Piggy-Back (SMA order number: 485PB-MS-NR), Radio Piggy-Back (SMA order number: BEAMPB-NR).



When opening the Sunny Boy, follow all the safety instructions as described in section 3.



Electrostatic discharges are an acute danger to the Sunny Boy and its communications interface. Ground yourself by touching PE before removing the communications interface from the packaging, and before touching any components within the Sunny Boy.



Read the communication device manual before beginning installation work. Further wiring details can be found there.

1. Open the inverter as described in section 7.1.
2. Guide the PG screw fitting over the communication cable.
3. Thread the cable through one of the cable feed-throughs (A) on the Sunny Boy. Use one or two cable feed-throughs, depending on the type of cable. Use the right-hand housing feed-through for the Radio Piggy-Back.
4. Screw the PG screw fitting onto the Sunny Boy.
5. Sheathe the cable inside the Sunny Boy using the silicone tube provided. The silicone tube is imperative for safety reasons. The interface is not to be operated without this silicone tube (with the exception of the Radio Piggy-Back).
6. Lay the cable in area (B) as shown in the figure to the right.
7. Ground the cable shield at the PE connector (C) if the terminal connection diagram of the communication device indicates this as necessary.
8. Connect the communication wires to the screw terminal strip (D) as described in the terminal connection diagram of the communication device. Note down the connector color coding for the respective pin numbers. Connecting the receiver incorrectly can cause the devices to be damaged.
 - Pin 2 color: _____
 - Pin 3 color: _____
 - Pin 5 color: _____
 - Pin 7 color: _____

9. Connect the jumpers (E) if the terminal connection diagram of the communication device indicates this as necessary. The table below provides an overview of the jumper functions.
10. Plug the communications interface to the left of the board (F).
11. Close the Sunny Boy as described in section 7.2.

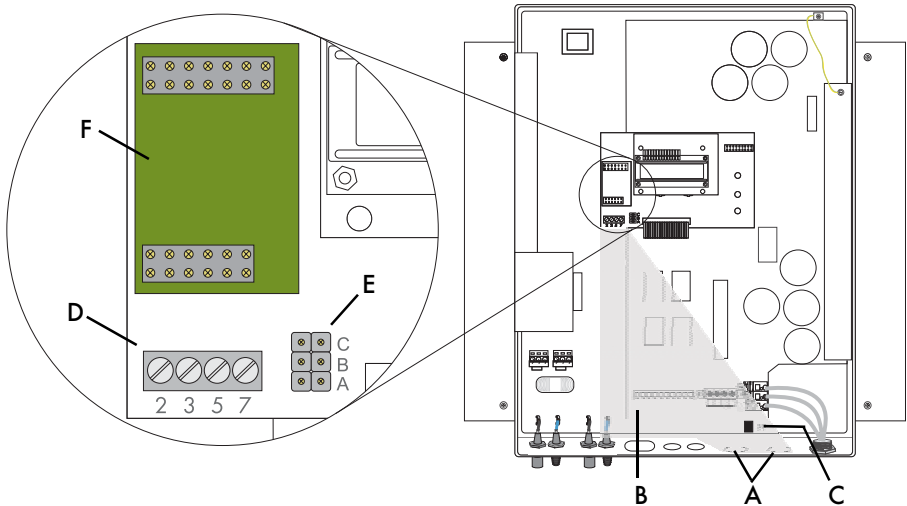

- A Housing feed-throughs in the base of the Sunny Boy
- B Cable route (gray surface)
- C PE connector
- D Screw terminals for connection of the communication wires
- E Jumper slot
- F Interface port

11.1.1 Jumper Functions

	Jumper A	Jumper B	Jumper C
RS232	-	-	-
RS485	Termination	Bias 1	Bias 2
Radio Piggy-Back	-	-	-

A detailed description of the jumper functions can be found in the communication device manual.

11.2 Powerline Connection

This section describes the installation of the "Powerline Kit" (SMA order number: NLMPB-MS-NR) for the mains grid communication in a Sunny Boy.



When opening the Sunny Boy, follow all the safety instructions as described in section 3.



Electrostatic discharges are an acute danger to the Sunny Boy and its communications interface. Ground yourself by touching PE before removing the communications interface from the packaging, and before touching any components within the Sunny Boy.



Read the communication device manual before beginning installation work. Further wiring details can be found there.

Two component groups must be installed in the Sunny Boy in order to allow mains grid communication. These component groups and a support for the power module are included in the "Powerline Kit" (SMA order number: NLMPB-MS-NR):

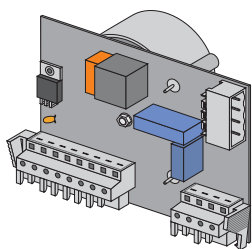

PLC power module

Powerline modem (NLM Piggy-Back)

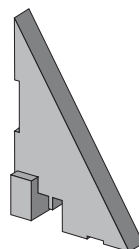
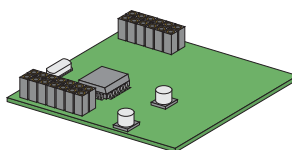

Support for the PLC power module



The Sunny Boy can only be operated with a powerline modem (NLM Piggy-Back) with version identifier "F" or higher. When installing the other (older) Piggy-Backs, mains grid connection is not possible. Please use therefore the powerline modem (NLM Piggy-Back) which is included in the "Powerline Kit".

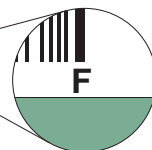
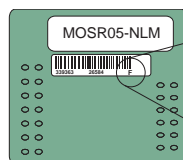

1. Open the inverter as described in section 7.1.
2. Press the lockings at the sides of the plug connector and remove them as displayed in the figure below.

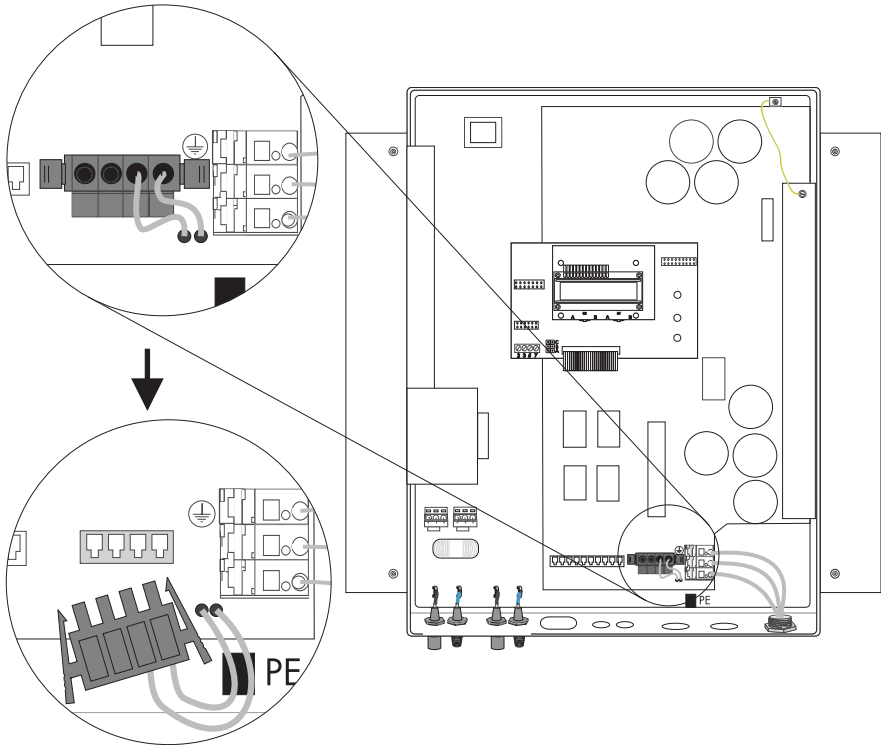

3. Plug the NLM Piggy-Back onto the board (F). Do not mount any jumpers.
4. Place the supplied support (G) of the PLC power module into the socket shown in the figure (far right). The support must audibly click into position.
5. Then insert the PLC power module (H) in the socket shown in the figure. The PLC power module must audibly click.
6. Place the plug connector in the free socket of the PLC power module.
7. Close the Sunny Boy as described in section 7.2.

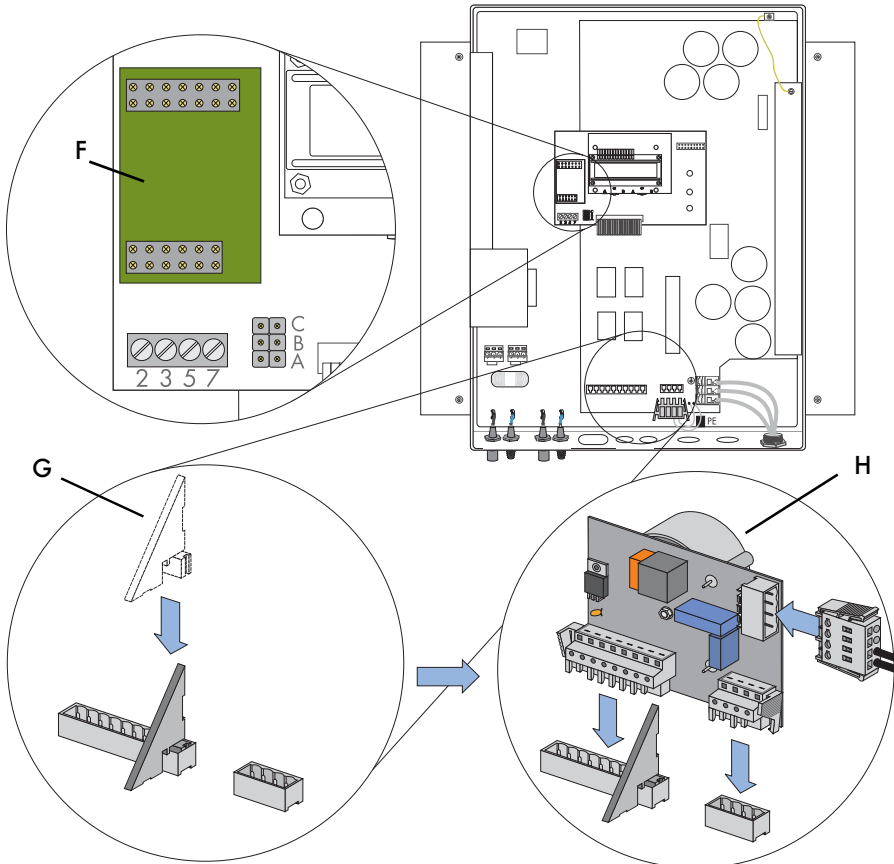

- F Interface port
- G Support
- H PLC power module

Notes on the Various Variants of the PLC Power Module

Various variants of the PLC power module may be supplied. The modules only differ in the positions of the sockets which are either arranged horizontally or vertically (see figure).

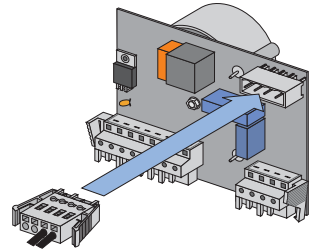

12 Contact

If you have any questions or technical problems concerning the Sunny Boy SB 3300TL HC, contact our hotline. Have the following information available when you contact SMA:

- Inverter type
- Type and number of modules connected
- Communication
- Serial number of the Sunny Boy
- Blink code or display of the Sunny Boy



Address:

SMA Technologie AG

Hannoversche Straße 1 - 5

34266 Niestetal

Germany

Tel.:+49 (561) 95 22 - 499

Fax:+49 (561) 95 22 - 4699

hotline@SMA.de

www.SMA.de

The information contained in this document is the property of SMA Technologie AG. Publishing its content, either partially or in full, requires the written permission of SMA Technologie AG. Any internal company copying of the document for the purposes of evaluating the product or its correct implementation is allowed and does not require permission.

Exclusion of liability

The general terms and conditions of delivery of SMA Technologie AG shall apply.

The content of these documents is continually checked and amended, where necessary. However, discrepancies cannot be excluded. No guarantee is made for the completeness of these documents. The latest version is available on the Internet at www.SMA.de or from the usual sales channels.

Guarantee or liability claims for damages of any kind are excluded if they are caused by one or more of the following:

- Improper or inappropriate use of the product
- Operating the product in an unintended environment
- Operating the product whilst ignoring relevant, statutory safety regulations in the deployment location
- Ignoring safety warnings and instructions contained in all documents relevant to the product
- Operating the product under incorrect safety or protection conditions
- Altering the product or supplied software without authority
- The product malfunctions due to operating attached or neighboring devices beyond statutory limit values
- In case of unforeseen calamity or force majeure

Software licensing

The use of supplied software produced by SMA Technologie AG is subject to the following conditions:

This software may be copied for internal company purposes and may be installed on any number of computers. Supplied source codes may be changed or adapted for internal company purposes on your own responsibility. Drivers may also be transferred to other operating systems. Source codes may only be published with the written permission of SMA Technologie AG. Sub-licensing of software is not permissible.

Limitation of liability: SMA Technologie AG rejects any liability for direct or indirect damages arising from the use of software developed by SMA Technologie AG. This also applies to the provision or non-provision of support activities.

Supplied software not developed by SMA Technologie AG is subject to the respective licensing and liability agreements of the manufacturer.

Trademarks

All trademarks are recognized even if these are not marked separately. Missing designations do not mean that a product or brand is not a registered trademark.

SMA Technologie AG
Hannoversche Straße 1-5
34266 Niestetal
Germany
Tel. +49 561 9522-0
Fax +49 561 9522-100
www.SMA.de
E-mail: info@SMA.de
© 2005 SMA Technologie AG. All rights reserved.

Sales
Solar Technology

www.SMA.de

SMA Technologie AG
Hannoversche Strasse 1-5
34266 Niestetal, Germany
Tel.: +49 561 9522 4000
Fax: +49 561 9522 4040
E-Mail: Info@SMA.de
Freecall: +800 SUNNYBOY
Freecall: +800 78669269



Innovation in Systems Technology
for the Success of Photovoltaics

